

DENON

Hi-Fi Component Amplifier

SERVICE MANUAL MODEL PMA-850 SOLID STATE STEREO INTEGRATED AMPLIFIER



TABLE OF CONTENTS

SPECIFICATIONS	1
BLOCK DIAGRAM	2
METHOD OF ADJUSTMENTS	2
EXPLODED VIEW OF CHASSIS AND CABINET	
FRONT SIDE	3
BACK SIDE	4
PRINTED CIRCUIT BOARD PATTERNS AND PARTS LIST	
INPUT TERMINAL UNIT ETC-261	5
CONTROL (A) UNIT ETC-259-1, -2, -3	5
CONTROL (B) UNIT ETC-260	8
POWER AMP UNIT PUX-017B-L, -R	10
POWER SWITCH & PROTECTOR UNIT ETC-262	12
CHASSIS AND CABINET GROUP PARTS LIST	16
WIRING DIAGRAM	15

NIPPON COLUMBIA CO., LTD.

SPECIFICATIONS

MAIN AMPLIFIER SECTION

Type:	All stages pure complementary pushpull system DC circuit
Rated Output (Both channels driven)	
20 Hz to 20 kHz:	85 W r.m.s. at each channel (T.H.D. 0.01% at 8 ohm)
1 kHz:	110 W r.m.s. at each channel (T.H.D. 0.05% at 4 ohm)
Total Harmonic Distortion:	less than 0.01%
Intermodulation Distortion	
60 Hz/7 kHz = 4/1:	less than 0.02% (at equivalent rated output)
Power Band width:	less than 0.01% (at 1 watt output)
Transmission Characteristic:	5 Hz to 100 kHz (IHF, T.H.D. 0.1%)
Input Sensitivity:	DC to 100 kHz +0 dB, -1 dB (at 1 watt output)
Input Impedance:	1 volt r.m.s.
Output Impedance:	50 k ohm
Signal to Noise Ratio:	less than 0.16 ohm
Output Terminals	122 dB
Speaker:	A & B, 4 to 16 ohm load
Headphone:	A + B, 8 to 16 ohm load for Stereo Headphone

PRE AMPLIFIER SECTION

Pre Amplifier Output	
Max. Output:	25 V (at 50 k ohm)
Rated Output:	1 V
Total Harmonic Distortion:	0.003% (at 3 V output)
Equalizer Amplifier Output	
Max. Output:	25 V (T.H.D. 0.01% at 50 k ohm load)
Rated Output:	320 mV
Input Sensitivity/Input Impedance	
Phono-1, 2 (MM):	2.5 mV/50 k ohm
Phono-3 (MC):	0.37 mV (cartridge impedance 40 ohm)
Tuner:	320 mV/40 k ohm
Aux, Tape:	320 mV/40 k ohm
Maximum Allowable Input	
Phono MM:	200 mV 1 kHz
Phono MC:	30 mV (1 kHz, 40 ohm)
RIAA Deviation:	less than ± 0.2 dB (20 Hz to 20 kHz)
Signal to Noise Ratio (IHF, A network)	
Phono MM:	Better than 89 dB (input terminal shorted)
Phono MC:	Better than 74 dB (input terminal 40 ohm)
Tuner, Tape, Aux:	Better than 105 dB (input terminal shorted)
Aux \rightarrow Pre Out Frequency Response	
Tone Defeat:	5 Hz to 100 kHz +0 dB, -1 dB
Tone Control Section Variable Range	
Bass:	100 Hz ± 8 dB
Treble:	10 kHz ± 8 dB
Filter Characteristic	
Subsonic:	20 Hz, 12 dB/oct
High Cut:	9 kHz, 12 dB/oct
Loudness Control Characteristic	
Low range:	100 Hz +7 dB
High range:	10 kHz +6 dB
Muting Level:	-20 dB

POWER SOURCE: AC 120 V, 60 Hz or AC 220 V, 50 Hz

POWER CONSUMPTION: 220W (for U.S.A.)
600 W (at max. output power)

AC OUTLET (for USA and Canada):

 UNSWITCHED: 150 W Max.

 SWITCHED: 250 W Max.

DIMENSIONS:

434 mm (W) \times 164 mm (H) \times 400 mm (D)

17-5/64" (W) \times 6-29/64" (H) \times 15-3/4" (D)

WEIGHT:

17 kg, 37.5 lbs.

These contents are subject to alteration without prior notice.

BLOCK DIAGRAM

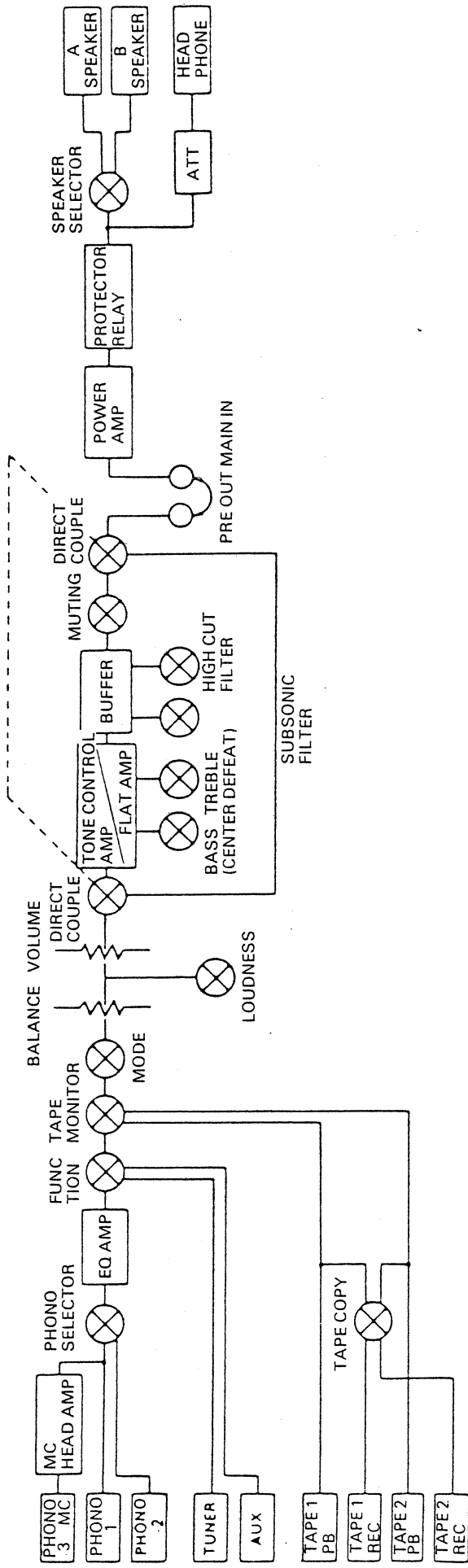

METHOD OF ADJUSTMENTS

STEP	ITEM	UNIT	SIGNAL	SETTING	INDICATOR		ADJUST	ADJUST LIMITS	REMARK
					TYPE	CONNECTED TO			
1	Center potential	PUX-017B-L(-R)	No signal	VOLUME minimum MUTING - 20 dB	VOLUME minimum MUTING - 20 dB	Oscilloscope DC terminal or DC Volt meter = 100 mV	VR1 (VR2)	0 ± 50 mV	Wait three minutes after Power switch is ON.
2	Power TR Idleing current	PUX-017B-L(-R)	No signal	VOLUME minimum MUTING - 20 dB	VOLUME minimum MUTING - 20 dB	Oscilloscope DC terminal or DC Volt meter = 100 mV	VR3 (VR4)	19 mV ± 5 mV (40 mA ± 10 mA)	Wait three minutes after Power switch is ON.

EXPLODED VIEW OF CHASSIS AND CABINET FRONT SIDE

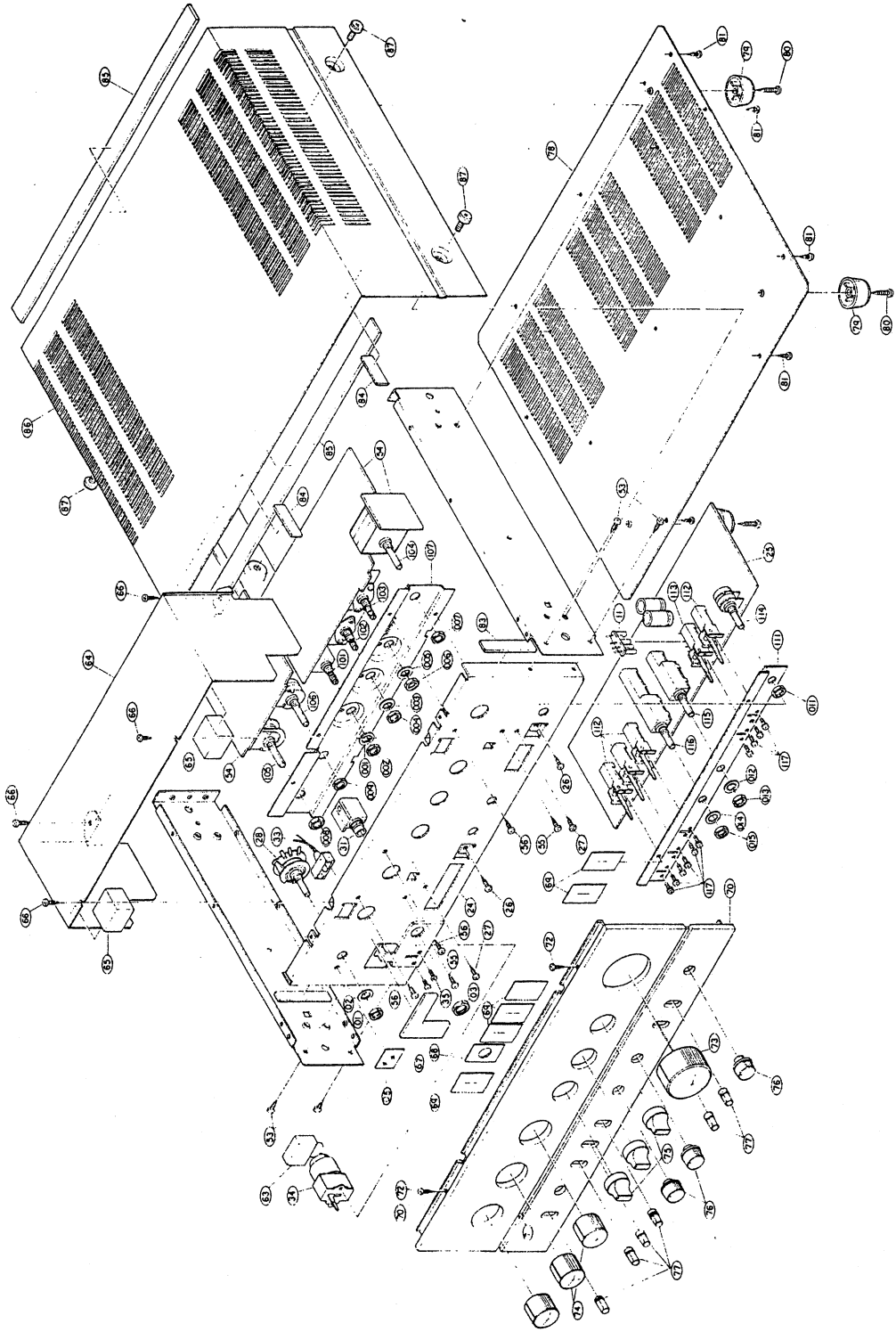

Ref. No.	Part No.	Description
1	1060191308	BACK PANEL
2	ETC-261	INPUT TERMINAL UNIT
3	4770064107	FIXING SCREW
4	2066070004	8P. TERMINAL ASS.
5	4770064107	FIXING SCREW
6	2066071003	TERMINAL ASS.
7	4770018001	WASHER
8	2036043000	4P. CONNECTOR BASE
9	2034106020	3P. CONNECTOR CORD
10	2034106017	3P. CONNECTOR CORD
11	2036071001	4P. CONNECTOR CORD
12	4770064107	FIXING SCREW
13	4140057100	BOARD BRACKET
14	2020011006	FUSE HOLDER
15	4120238101	BRACKET
16	4700060006	3 x 6 CFS SW
17	4770064107	FIXING SCREW
18	5130138067	FUSE LABEL
19	2066029009	AC CORD WITH PLUG
20	4460020005	CORD BUSH
21	2033904003	AC OUTLET
22	4711304033	3 x 8 CPS
23	2061015067	FUSE (4A)
24	4110114026	FRONT CHASSIS
25	ETC-260	CONTROL (BL) UNIT
26	4770064107	FIXING SCREW
27	4730053036	3 x 6 CBRITS
28	2120119002	SPEAKER SWITCH
01		9 NSP
02		9 TWA
29	2030014036	1P. CONNECTOR (PI) ASS
30	2030014048	1P. CONNECTOR (PI) ASS
31	2048011004	HEAD PHONE JACK
03		11N
32	2094106005	3P. CONNECTOR CORD
33	3930032019	PLG. 3V. 0.15A
04		2P. MINI CONNECTOR
34	2124111006	LEVER SWITCH
35	4711304033	3 x 8 CPS
06		MAIN CHASSIS
36	4110114202	ADHESION TAPE
37	MD-5271	PCB SUPPORT
38	MD-4368	WIRE CLIP
39	MD-4232	WIRE CLIP (D)
40	2546028007	10000.0 F CAPACITOR
41	4730053035	3 x 8 CBRITS
42	2034093010	3P. CONNECTOR CORD
43	2034093049	3P. CONNECTOR CORD
44	2060095102	EARTH PLATE
45	4770064107	FIXING SCREW
46	PLX-017L	POWER AMP UNIT (L)
47	4770064107	FIXING SCREW
48	PLX-017R	POWER AMP UNIT (R)
49	4770064107	FIXING SCREW
50	4110116008	SIDE CHASSIS
51	4730053036	3 x 6 CBRITS
52	4770064107	FIXING SCREW
53	4770064107	FIXING SCREW
54	ETC-259	CONTROL (A) UNIT
55	4770064107	FIXING SCREW
56	4730053036	3 x 6 CBRITS
57	2330100102	3 x 6 CBRITS
58	4756012005	POWER TRANSFORMER ASS
59	4752006002	6 SW
60	ETC-262	P. S. F. PROT UNIT
61	2066037005	SHORT PIN
62	2518001007	0.01 F CAPACITOR
63	2518001007	SHIELD COVER
64	4140114205	BLIND
65	4610074176	BLIND
66	4770064107	FIXING SCREW
67	4610074150	BLIND
68	1220050004	BLIND SHEET
69	1190005040	BLIND SHEET
70	1440344202	FRONT PANEL
71	1430041007	PILOT LENS
72	4730053035	3 x 8 CBRITS
73	1720180007	KNOB ASS.

BACK SIDE

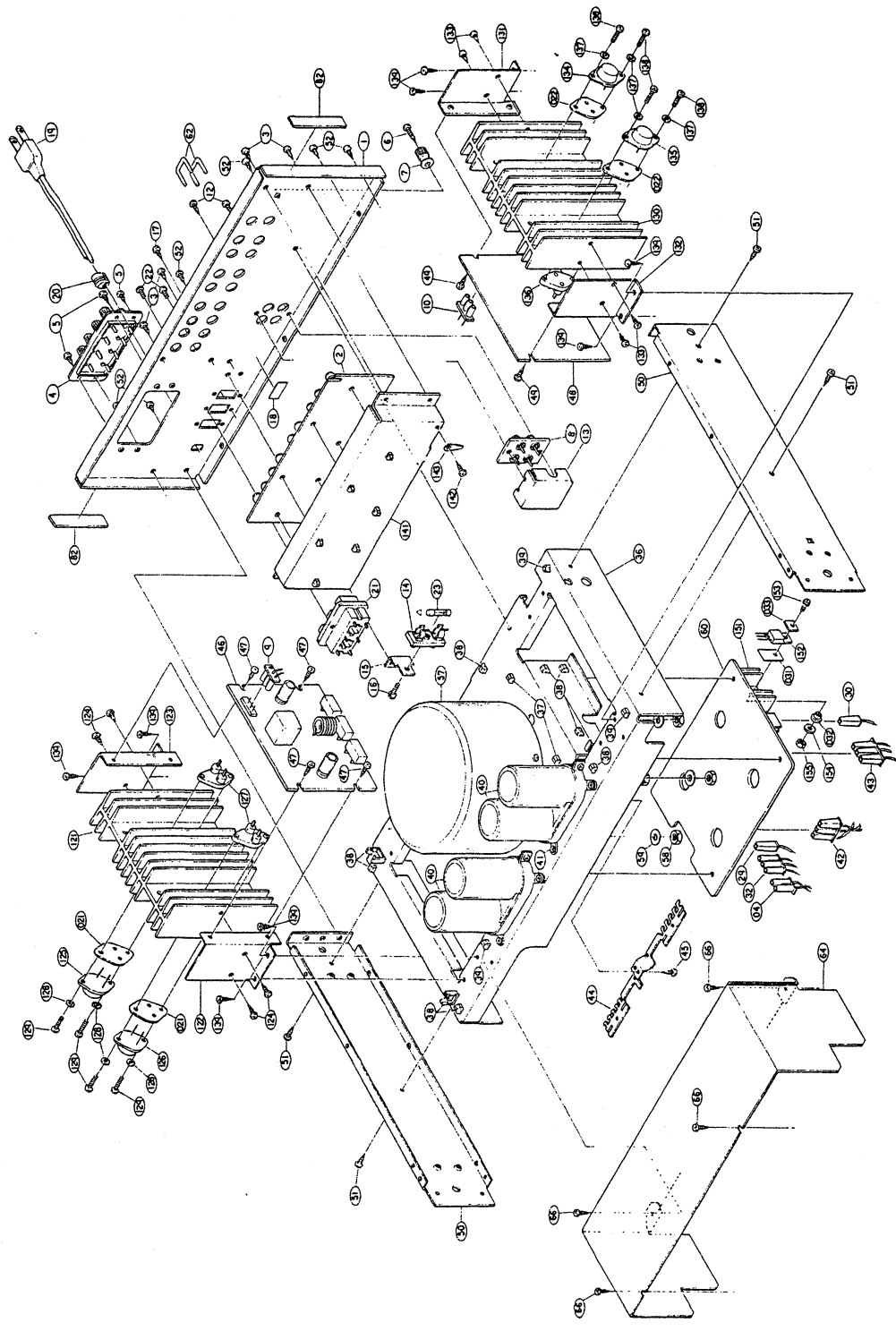

Ref. No.	Part No.	Description
74	1120161006	KNOB ASS.
75	1120162009	KNOB ASS.
76	1120163101	KNOB ASS.
77	1120166108	LEVER KNOB
78	1050188308	BOTTOM COVER
79	1040040003	FOOT
80	4730450114	4x12 CBRTS
81	4770064107	FIXING SCREW
82	4610061118	RUBBER SHEET
83	4610061121	RUBBER SHEET
84	4610094017	RUBBER SHEET
85	1220007057	SPACER
86	1020063107	TOP COVER
87	SC-1162	SPECIAL SCREW
101	4110145107	CONTROL BRACKET (A)
101	2120114007	ROTARY SWITCH
001		7 TWA
002		7 NSP
102	2120116006	FUNCTION SWITCH
003		9 TWA
004		9 NSP
103	2120116005	ROTARY SWITCH
005		9 TWA
006		9 NSP
104	2110180100	V2E20V20RE4903
105	2110161002	V2420V20RE104
008		8 NSP
106	2110162001	V2420V20RE104
009		8 NSP
111	4110146106	CONTROL BRACKET (B)
112	2124110007	LEVER SWITCH
113	2124110010	LEVER SWITCH
117	4700069006	3x6 CPS (SW)
114	2110163107	V1620V25RW104K
011		7 NSP
115	2120117004	ROTARY SWITCH
012		7 TWA
013		7 N
116	2120118003	ROTARY SWITCH
014		7 TWA
015		7 N
121	4170077105	POWER RADIATOR
122	4120372009	RADIATOR BRACKET (A)
123	4120373008	RADIATOR BRACKET (B)
124	4770064107	FIXING SCREW
125	2710069001	2SA1007A (OI)
126	2730189008	2SC2327A (OI)
021		INSULATION SHEET
127	2070002007	TR SOCKET
128		3 TWA
129	4763001051	3x18 CPS
130	4718069033	3x18 CPS
131	4170077105	POWER RADIATOR
132	4120372009	RADIATOR BRACKET (A)
133	4120373008	RADIATOR BRACKET (B)
134	4770064107	FIXING SCREW
135	2710069001	2SA1007A (OI)
136	2730189008	2SC2327A (OI)
022		INSULATION SHEET
137	2070002007	TR SOCKET
138		3 TWA
139	4763001051	3x18 CPS
140	4718069033	3x18 CPS
141	4730354035	3x8 CBRTS
142	414013002	INPUT BRACKET
143	4730353036	3x6 CBRTS
144	2050003000	3T LUG
151	4170078201	RADIATOR
152	2749044010	2SD478 (CI)
153	4700012006	3x12 CPS (SW)
154	4761003006	3W
155	4756006008	3N
031		INSULATION SHEET SK 10B
032		INSULATION BUSH YD2D
033		WASHER Y20315

PRINTED CIRCUIT BOARD PATTERNS AND PARTS LIST

INPUT TERMINAL UNIT ETC-261

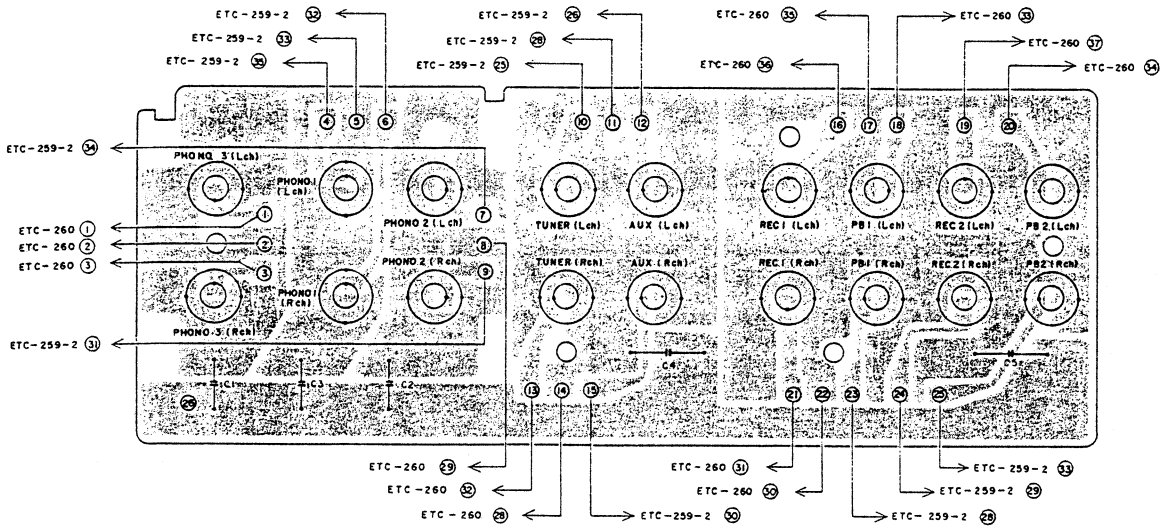
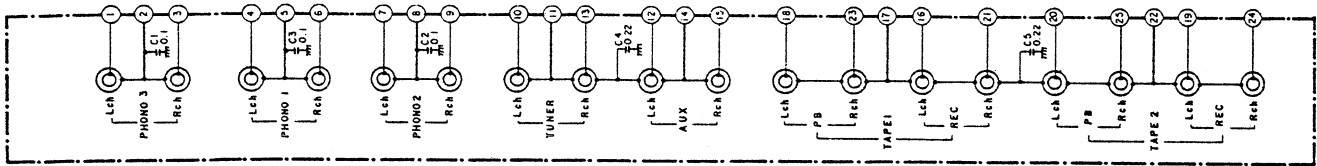

ETC-261 PARTS LIST

Ref. No.	Part No.	Descriptions
CAPACITORS		
C1, 2, 3	2531027000	100000 pF +80, -20% 50 V CERAMIC CAPACITOR
C4, 5	2551088003	0.22 μF ±10% 50 V PLASTIC FILM CAPACITOR
OTHER PARTS		
	4140113002	INPUT BRACKET
	MD-5271	P.C.B. HOLDER

CONTROL (A) UNIT ETC-259-1, -2, -3

TONE UNIT (1)

(1)

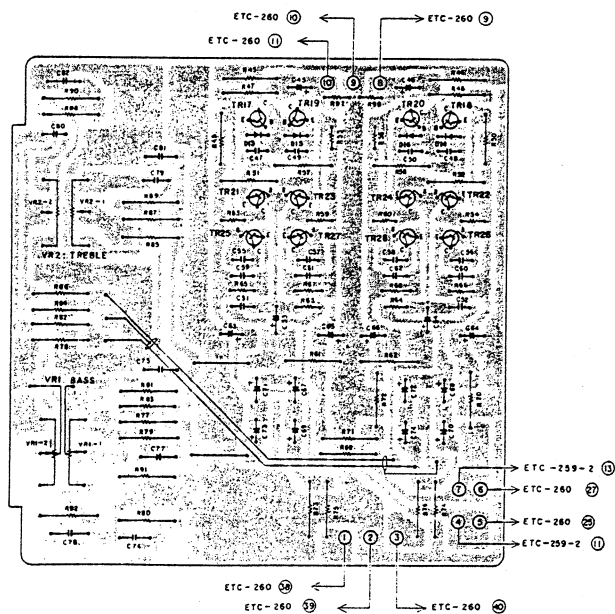
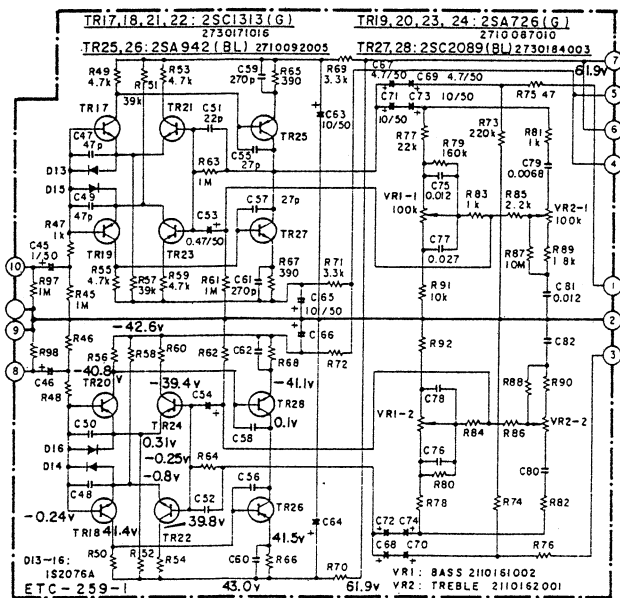

EQUALIZER AMP UNIT (2)

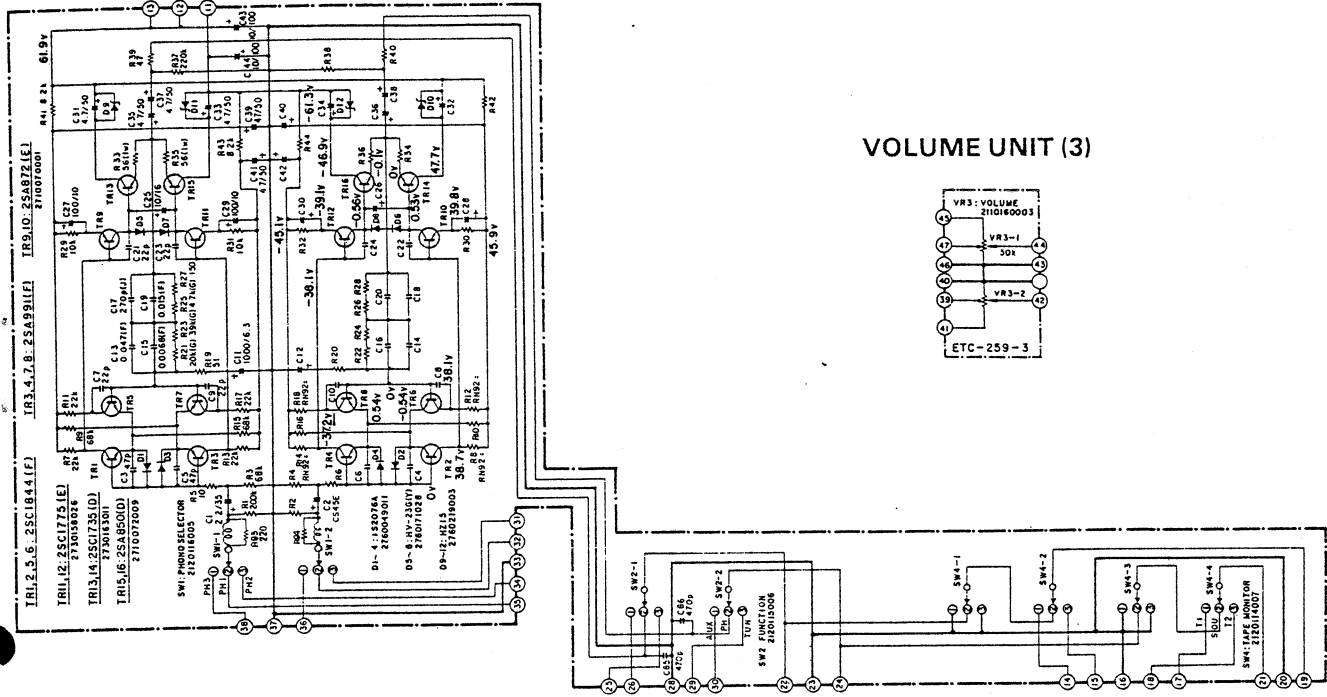

CONTROL (A) UNIT ETC-259 (ETC-259C)

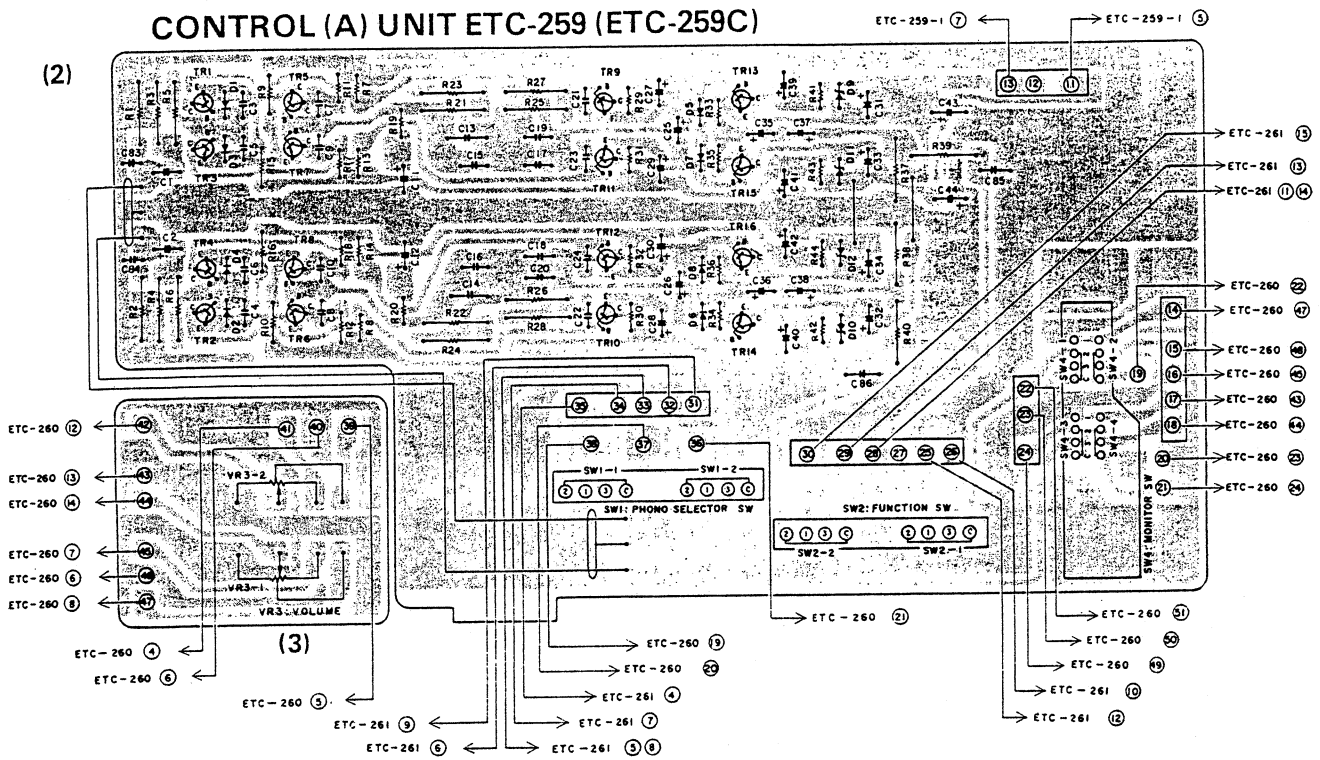

ETC-259 PARTS LIST

Ref. No.	Part No.	Descriptions
SEMICONDUCTORS		
TR1, 2, 5, 6	2730188009	2SC1844 (F) TRANSISTOR
TR3, 4, 7, 8	2710095002	2SA991 (F) TRANSISTOR
TR9, 10	2710070001	2SA872 (E) TRANSISTOR
TR11, 12	2730158026	2SC1775 (E) TRANSISTOR
TR13, 14	2730163011	2SC1735 (D) TRANSISTOR
TR15, 16	2710072009	2SA850 (D) TRANSISTOR
TR17, 18, 21, 22	2730171016	2SC1313 (G) TRANSISTOR
TR19, 20, 23, 24	2710087010	2SA726 (G) TRANSISTOR
TR25, 26	2710092005	2SA942 (BL) TRANSISTOR
TR27, 28	2730184003	2SC2089 (BL) TRANSISTOR
D1, 2, 3, 4, 13, 14, 15, 16	2760049011	1S2076A DIODE
D5, 6, 7, 8	2760171028	HV23G (Y) DIODE
D9, 10, 11, 12	2760219003	HZ15 DIODE

Ref. No.	Part No.	Descriptions			
INDUCTORS					
L1, 2	2318017000				
CAPACITORS					
C1, 2	2541031002	2.2 μ F	$\pm 20\%$	35 V	TANTALUM SOLID CAPACITOR
C3, 4, 5, 6, 47, 48, 49, 50	2533653003	47 pF	$\pm 10\%$	50 V	CERAMIC CAPACITOR
C11, 12	2544007004	1000 μ F		6.3 V	ELECTROLYTIC CAPACITOR
C13, 14	2554075000	0.047 μ F	$\pm 1\%$	100 V	PLASTIC FILM CAPACITOR
C15, 16	2554070034	0.0068 μ F	$\pm 1\%$	100 V	PLASTIC FILM CAPACITOR
C17, 18	2533637003	270 pF	$\pm 5\%$	50 V	CERAMIC CAPACITOR
C19, 20	2554073086	0.015 μ F	$\pm 1\%$	100 V	PLASTIC FILM CAPACITOR
C21, 22, 23, 24, 51, 52	2533649004	22 pF	$\pm 10\%$	50 V	CERAMIC CAPACITOR
C25, 26	2544015009	10 μ F		16 V	ELECTROLYTIC CAPACITOR
C27, 28, 29, 30	2544010004	100 μ F		10 V	ELECTROLYTIC CAPACITOR
C31, 32, 33, 34, 35, 36, 37, 38, 67, 68, 69, 70	2544046007	4.7 μ F		50 V	ELECTROLYTIC CAPACITOR
C39, 40, 41, 42	2544049004	47 μ F		50 V	ELECTROLYTIC CAPACITOR
C43, 44	2544060009	10 μ F		100V	ELECTROLYTIC CAPACITOR
C45, 46	2561008060	1 μ F	$\pm 10\%$	100 V	METALIZED CAPACITOR
C53, 54	2544043000	0.47 μ F		50 V	ELECTROLYTIC CAPACITOR
C55, 56, 57, 58	2533650006	270 pF	$\pm 10\%$	50 V	CERAMIC CAPACITOR
C59, 60, 61, 62	2533662007	270 pF	$\pm 10\%$	50 V	CERAMIC CAPACITOR
C63, 64, 65, 66, 71 72, 73, 74	2544047006	10 μ F		50 V	ELECTROLYTIC CAPACITOR
C75, 76, 81, 82	2551121038	0.012 μ F	$\pm 5\%$	50 V	PLASTIC FILM CAPACITOR
C77, 78	2551121070	0.027 μ F	$\pm 5\%$	50 V	PLASTIC FILM CAPACITOR
C79, 80	2551121009	0.0068 μ F	$\pm 5\%$	50 V	PLASTIC FILM CAPACITOR
C83, 84	2533658008	220 pF	$\pm 10\%$	50 V	CERAMIC CAPACITOR
C85, 86	2551068007	0.0047 μ F	$\pm 10\%$	50 V	PLASTIC FILM CAPACITOR
C91, 92	2541001003	4.7 μ F	$\pm 20\%$	6.3 V	TANTALUM SOLID CAPACITOR
RESISTORS					
R1, 2	2410369009	200 ohm	$\pm 5\%$	1/4 W	CARBON FILM RESISTOR
R3, 4	2410358007	68 kohm	$\pm 5\%$	1/4 W	CARBON FILM RESISTOR
R5, 6	2410284003	56 ohm	$\pm 5\%$	1/4 W	CARBON FILM RESISTOR
R7, 8, 11, 12, 13 14, 17, 18	2452011085	22 kohm	$\pm 1\%$	1/4 W	METAL OXIDE FILM RESISTOR
R9, 10, 15, 16	2412003004	68 kohm	$\pm 5\%$	1/4 W	CARBON FILM RESISTOR
R19, 20	2412026052	51 ohm	$\pm 5\%$	1/4 W	CARBON FILM RESISTOR
R21, 22	2412012053	20 kohm	$\pm 2\%$	1/4 W	CARBON FILM RESISTOR
R23, 24	2412032059	39 kohm	$\pm 2\%$	1/4 W	CARBON FILM RESISTOR
R25, 26	2412032046	4.7 kohm	$\pm 2\%$	1/4 W	CARBON FILM RESISTOR
R27, 28	2410294006	150 ohm	$\pm 5\%$	1/4 W	CARBON FILM RESISTOR
R29, 30, 31, 32	2412020090	10 kohm	$\pm 5\%$	1/4 W	CARBON FILM RESISTOR
R33, 34, 35, 36	2440026008	56 ohm	$\pm 5\%$	1 W	METAL OXIDE FILM RESISTOR
R37, 38, 73, 74	2410370001	220 kohm	$\pm 5\%$	1/4 W	CARBON FILM RESISTOR
R39, 40, 75, 76	2410282005	47 ohm	$\pm 5\%$	1/4 W	CARBON FILM RESISTOR
R41, 42, 43, 44	2412020087	82 kohm	$\pm 5\%$	1/4 W	CARBON FILM RESISTOR
R45, 46, 61, 62, 97, 98	2410765001	1 Mohm	$\pm 5\%$	1/4 W	CARBON FILM RESISTOR
R47, 48, 81, 82, 83, 84	2410314009	1 kohm	$\pm 5\%$	1/4 W	CARBON FILM RESISTOR
R49, 50	2410330009	4.7 kohm	$\pm 5\%$	1/4 W	CARBON FILM RESISTOR
R51, 52, 57, 58	2410352003	39 kohm	$\pm 5\%$	1/4 W	CARBON FILM RESISTOR
R53, 54, 55, 56, 59, 60	2412020058	4.7 kohm	$\pm 5\%$	1/4 W	CARBON FILM RESISTOR
R63, 64	2410773006	1 Mohm	$\pm 5\%$	1/4 W	CARBON FILM RESISTOR
R65, 66, 67, 68	2412002034	390 ohm	$\pm 5\%$	1/4 W	CARBON FILM RESISTOR
R69, 70, 71, 72	2410326000	3.3 kohm	$\pm 5\%$	1/4 W	CARBON FILM RESISTOR
R77, 78	2410346006	22 kohm	$\pm 5\%$	1/4 W	CARBON FILM RESISTOR
R79, 80	2410367001	160 kohm	$\pm 5\%$	1/4 W	CARBON FILM RESISTOR
R85, 86	2410322004	2.2 kohm	$\pm 5\%$	1/4 W	CARBON FILM RESISTOR
R87, 88	2420203003	10 Mohm	$\pm 10\%$	1/4 W	CARBON COMPOSITION RESISTOR
R89, 90	2410320006	1.8 kohm	$\pm 5\%$	1/4 W	CARBON FILM RESISTOR
R91, 92	2410338001	10 kohm	$\pm 5\%$	1/4 W	CARBON FILM RESISTOR
R93, 94	2412002005	220 ohm	$\pm 5\%$	1/4 W	CARBON FILM RESISTOR
OTHER PARTS					
SW1	2120116005	ROTARY SWITCH		FOR PHONO SELECT	
SW2	2120115006	FUNCTION SWITCH (ETC-259)		FOR FUNCTION	
SW2	2120129005	FUNCTION SWITCH (ETC-259C)		FOR FUNCTION	
SW4	2120114007	ROTARY SWITCH		FOR MONITOR	
VR1	2110161002	VARIABLE RESISTOR V2420V30RE104-		FOR BASS	
VR2	2110162001	VARIABLE RESISTOR V2420V30RE104-		FOR TREBLE	
VR3	2110160100	VARIABLE RESISTOR V3520V30RA503-		FOR MAIN VOLUME	
	4140116106	SHIELD COVER			
	4110145107	CONTROL BRACKET (A)			

CONTROL (B) UNIT ETC-260

TR1-4: 2SC1844 (F)
273018300g

TR5-8: 2SA991 (F)

TR9,10,15,16: 2SA726 (G)
2710087010

TR11-14: 2SC1313 (G)
2730171016

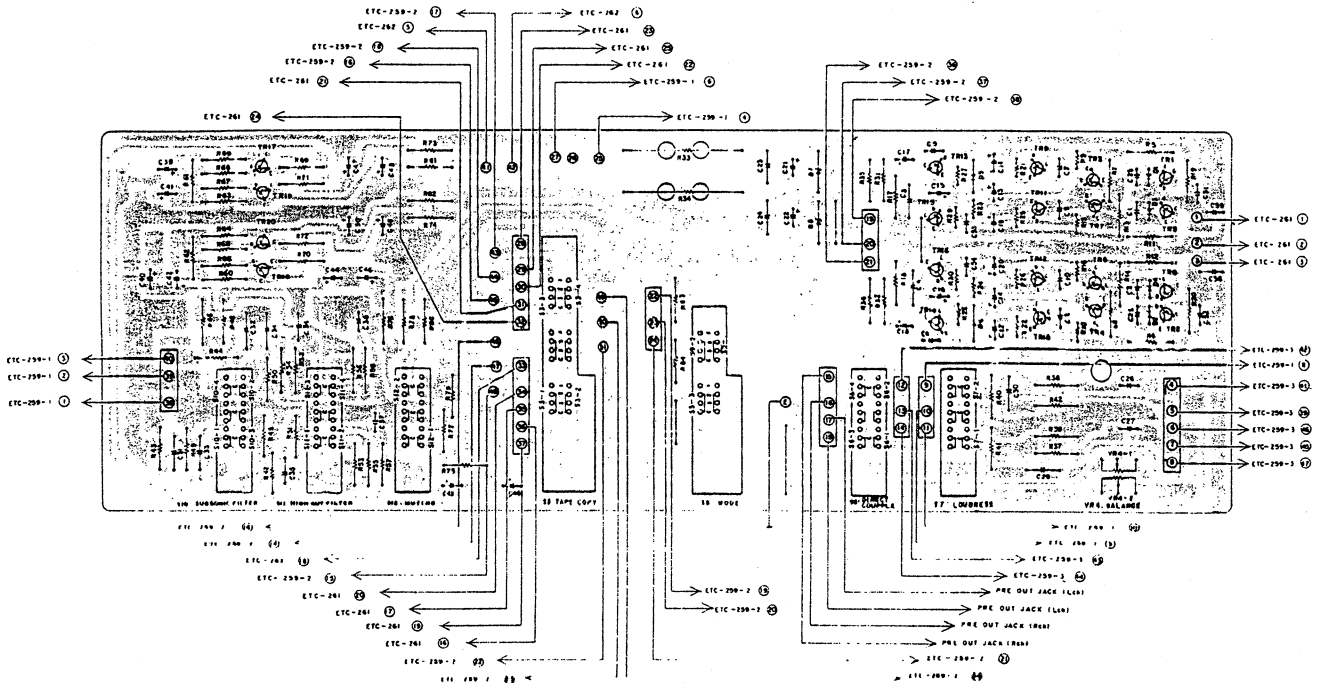
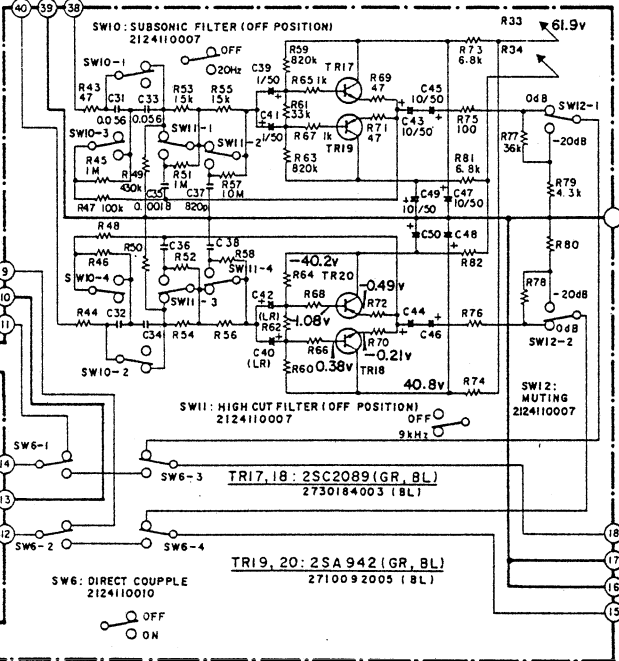
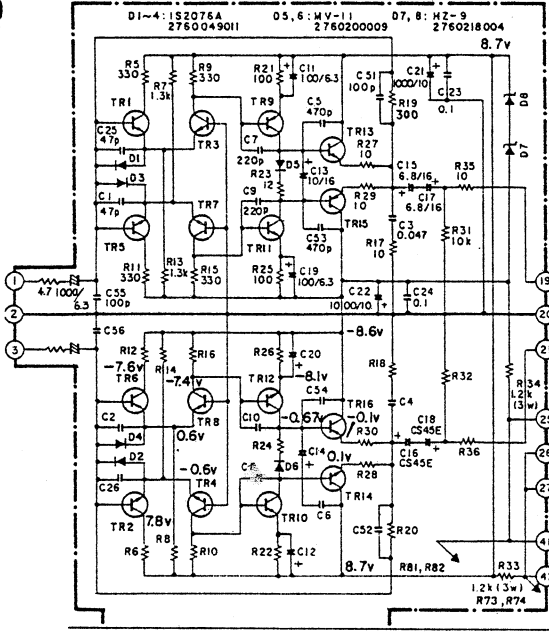
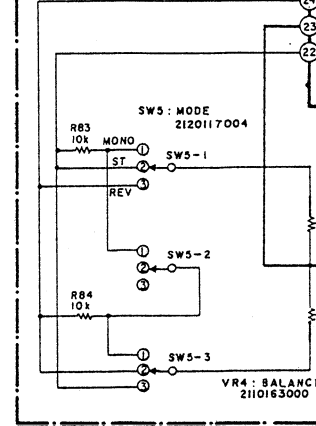
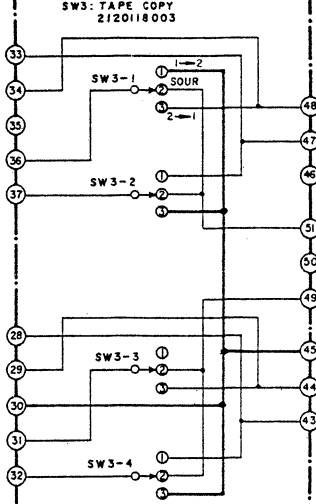

ETC-260 PARTS LIST

Ref. No.	Part No.	Descriptions			
SEMICONDUCTORS					
TR1, 2, 3, 4	2730188009	2SC1844 (F)			TRANSISTOR
TR5, 6, 7, 8	2710095002	2SA991 (F)			TRANSISTOR
TR9, 10, 15, 16	2710087010	2SA726 (G)			TRANSISTOR
TR11, 12, 13, 14	2730171016	2SC1313 (G)			TRANSISTOR
TR17, 18	2730184016	2SC2089 (GR)			TRANSISTOR
TR19, 20	2710092018	2SA942 (GR)			TRANSISTOR
D1, 2, 3, 4	2760049011	1S2076A			DIODE
D5, 6	2760200009	MV-11			DIODE
D7, 8	2760218004	HZ9			DIODE
CAPACITORS					
C1, 2, 25, 26	2533653003	4.7 pF	± 10%	50 V	CERAMIC CAPACITOR
C3, 4	2551080001	0.047 μF	± 10%	50 V	PLASTIC FILM CAPACITOR
C5, 6, 53, 54	2531002009	470 pF	± 10%	50 V	CERAMIC CAPACITOR
C7, 8, 9, 10	2533661008	220 pF	± 10%	50 V	CERAMIC CAPACITOR
C11, 12, 19, 20	2544003008	100 μF		6.3 V	ELECTROLYTIC CAPACITOR
C13, 14	2544015009	10 μF		16 V	ELECTROLYTIC CAPACITOR
C15, 16, 17, 18	2541017000	6.8 μF	± 20%	16 V	TANTALUM SOLID CAPACITOR
C21, 22	2544014000	1000 μF		10 V	ELECTROLYTIC CAPACITOR
C23, 24	2531027000	100000 pF + 80%, - 20%		50 V	CERAMIC CAPACITOR
C27, 28	2556096003	750 pF	± 5%	50 V	PLASTIC FILM CAPACITOR
C29, 30	2551122040	0.1 μF	± 10%	50 V	PLASTIC FILM CAPACITOR
C31, 32, 33, 34	2551122011	0.056 μF	± 5%	50 V	PLASTIC FILM CAPACITOR
C35, 36	2551120039	0.0018 μF	± 5%	50 V	PLASTIC FILM CAPACITOR
C37, 38	2556097002	820 pF	± 5%	50 V	PLASTIC FILM CAPACITOR
C39, 40, 41, 42	2549011008	1 μF		50 V	ELECTROLYTIC CAPACITOR
C43, 44, 45, 46	2544047006	10 μF		50 V	ELECTROLYTIC CAPACITOR
47, 48, 49, 50					
C51, 52, 55, 56	2533657009	100 pF	± 10%	50 V	CERAMIC CAPACITOR
RESISTORS					
R5, 6, 11, 12,	2410302008	330 ohm	± 5%	1/4 W	CARBON FILM RESISTOR
R7, 8, 13, 14	2410317006	1.3 kohm	± 5%	1/4 W	CARBON FILM RESISTOR
R9, 10, 15, 16	2412002021	330 ohm	± 5%	1/4 W	CARBON FILM RESISTOR
R17, 18, 35, 36	2410266005	10 ohm	± 5%	1/4 W	CARBON FILM RESISTOR
R19, 20	2410300000	270 ohm	± 5%	1/4 W	CARBON FILM RESISTOR
R21, 22, 25, 26	2412001064	100 ohm	± 5%	1/4 W	CARBON FILM RESISTOR
R23, 24	2412000052	12 ohm	± 5%	1/4 W	CARBON FILM RESISTOR
R27, 28, 29, 30	2412000049	10 ohm	± 5%	1/4 W	CARBON FILM RESISTOR
R31, 32, 83, 84	2410338001	10 kohm	± 5%	1/4 W	CARBON FILM RESISTOR
R33, 34	2440154006	1.2 kohm	± 5%	3 W	METAL OXIDE FILM RESISTOR
R37, 38, 53, 54, 55, 56	2410342000	15 kohm	± 5%	1/4 W	CARBON FILM RESISTOR
R39, 40, 57, 58	2420203003	10 Mohm	± 10%	1/4 W	CARBON COMPOSITION RESISTOR
R41, 42	2410325001	3 kohm	± 5%	1/4 W	CARBON FILM RESISTOR
R43, 44, 69, 70, 71, 72	2410282005	47 ohm	± 5%	1/4 W	CARBON FILM RESISTOR
R45, 46, 51, 52	2410765001	1 Mohm	± 5%	1/4 W	CARBON FILM RESISTOR
R47, 48	2410362006	100 kohm	± 5%	1/4 W	CARBON FILM RESISTOR
R49, 50	2410377004	430 kohm	± 5%	1/4 W	CARBON FILM RESISTOR
R59, 60, 63, 64	2410763003	820 kohm	± 5%	1/4 W	CARBON FILM RESISTOR
R61, 62	2410350005	33 kohm	± 5%	1/4 W	CARBON FILM RESISTOR
R65, 66, 67, 68	2410314009	1 kohm	± 5%	1/4 W	CARBON FILM RESISTOR
R73, 74, 81, 82	2410334005	6.8 kohm	± 5%	1/4 W	CARBON FILM RESISTOR
R75, 76	2410290000	100 ohm	± 5%	1/4 W	CARBON FILM RESISTOR
R77, 78	2410351004	36 kohm	± 5%	1/4 W	CARBON FILM RESISTOR
R79, 80	2410329007	4.3 kohm	± 5%	1/4 W	CARBON FILM RESISTOR
OTHER PARTS					
SW3	2120118003	ROTARY SWITCH			FOR TAPE COPY
SW5	2120117004	ROTARY SWITCH			FOR MODE
SW6	2124110010	LEVER SWITCH			FOR DIRECT COUPLE
SW7, 10, 11, 12	2124110007	LEVER SWITCH			FOR LOUDNESS SUBSONIC HIGHCUT AND MUTING
VR4	2110163107	VARIABLE RESISTOR V1620V25RW104K			FOR BALANCE
	4110146106	CONTROL BRACKET (B)			

POWER AMP UNIT PUX-017B - L, - R

(L)

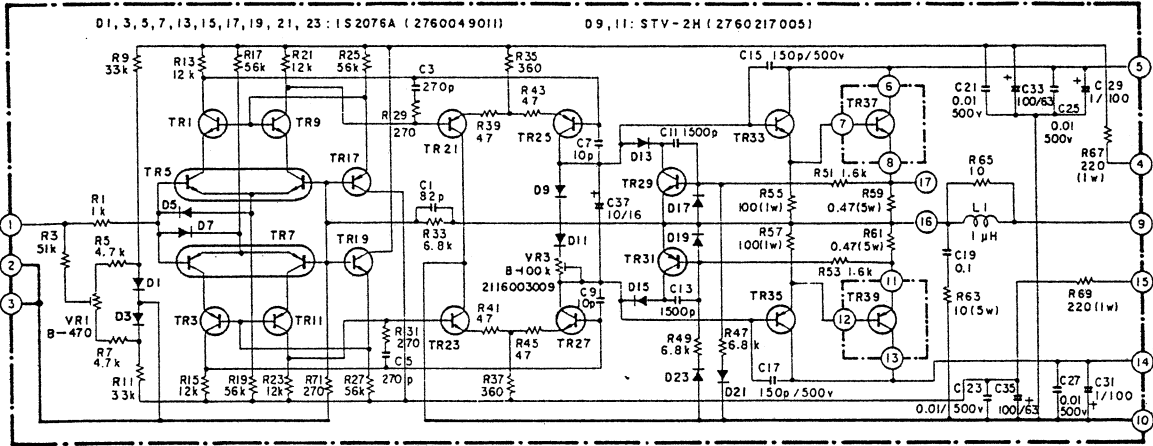

TR1, 9, 19: 2SC2089 (BL) 2730184003	TR3, 11, 17: 2SA942 (BL) 2710092005	TR5: 2SC1583 (G) 2730181006	TR7: 2SA798 (G) 2710073008
TR21, 25: 2SA915 (L) 2710093004	TR23, 27: 2SC1940 (L) 2730186001	TR29: 2SC1000 (GR) 2730098034	TR31: 2SA493 (GR) 2710012001
TR33: 2SC1624 (Y) 2730174000	TR35: 2SA814 (Y) 2710081003	TR37: 2SD511 (R) 2740056008	TR39: 2SB681 (R) 2720039003

(R)

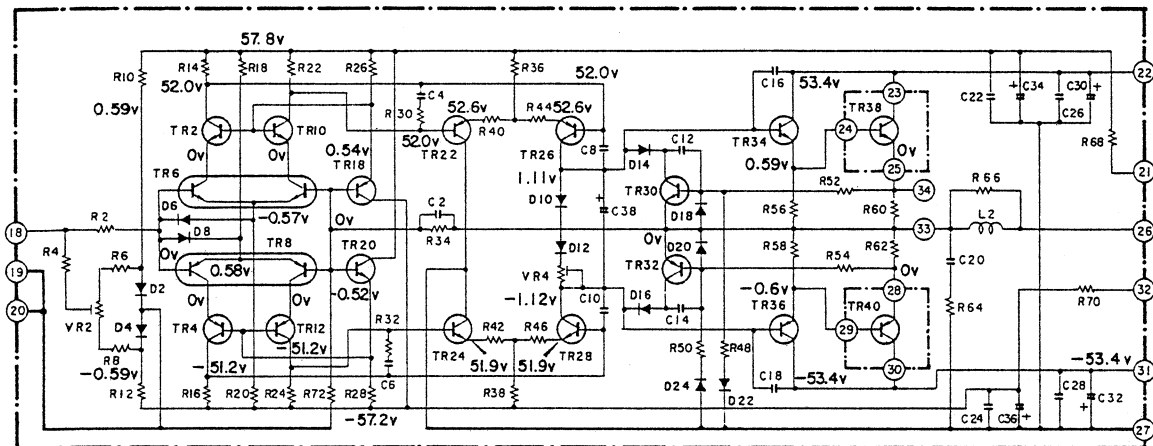

(L)

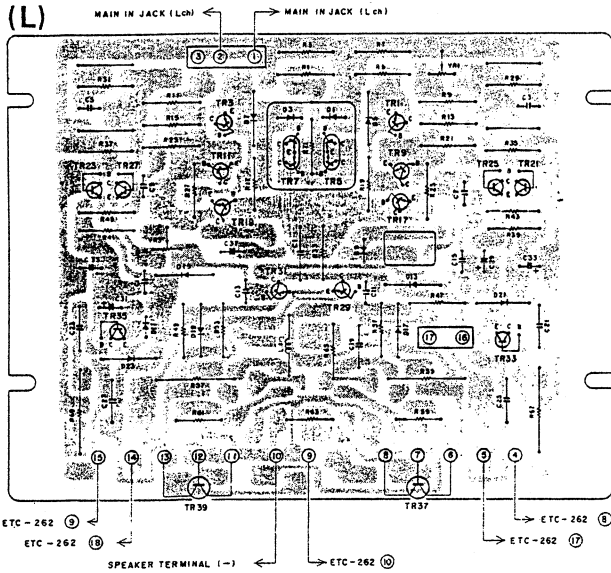

(R)

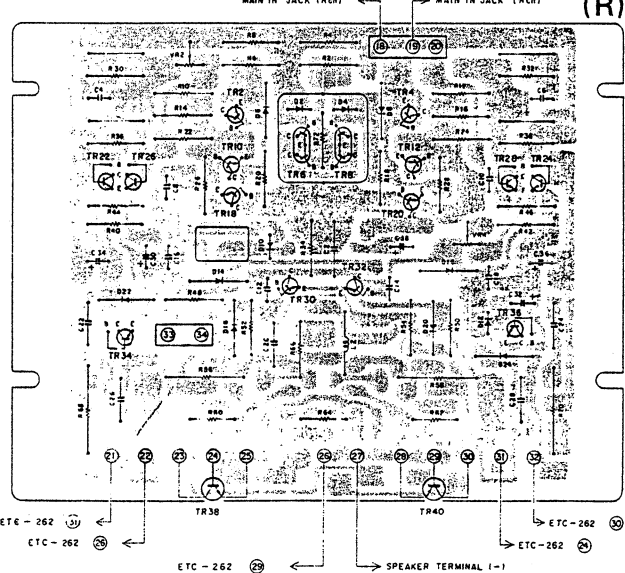

PUX-017B - L, - R

Ref. No.	Part No.	Descriptions
SEMICONDUCTORS		
TR1, 2, 9, 10, 19, 20	2730184003	2SC2089 (BL) TRANSISTOR
TR3, 4, 11, 12, 17, 18	2710092005	2SA942 (BL) TRANSISTOR
TR5, 6	2730181006	2SC1583 (G) TRANSISTOR
TR7, 8	2710073008	2SA798 (G) TRANSISTOR
TR21, 22, 25, 26	2710093004	2SA915 (L) TRANSISTOR
TR23, 24, 27, 28	2730186001	2SC1940 (L) TRANSISTOR
TR29, 30	2730098034	2SC1000 (GR) TRANSISTOR
TR31, 32	2710012001	2SA493 (GR) TRANSISTOR
TR33, 34	2730174000	2SC1624 (Y) TRANSISTOR
TR35, 36	2710081003	2SA814 (Y) TRANSISTOR
TR37, 38	2740056008	2SD511 (R) TRANSISTOR
TR39, 40	2720039003	2SB681 (R) TRANSISTOR

Ref. No.	Part No.	Descriptions			
D1, 2, 3, 4, 5, 6, 7, 8, 13, 14, 15, 16, 17, 18, 19, 20, 21, 22, 23, 24 D9, 10, 11, 12	2760049011	1S2076A			DIODE
	2760217005	STV-2H			DIODE
INDUCTORS					
L1, 2	2320017001	1 μ H			
CAPACITORS					
C1, 2	2533656000	82 pF	$\pm 10\%$	50 V	CERAMIC CAPACITOR
C3, 4, 5, 6	2533662007	270 pF	$\pm 10\%$	50 V	CERAMIC CAPACITOR
C7, 8, 9, 10	2534269001	10	$\pm 0.5\%$	500 V	CERAMIC CAPACITOR
C11, 12, 13, 14	2531005006	1500 pF	$\pm 10\%$	50 V	CERAMIC CAPACITOR
C15, 16, 17, 18	2534327008	150 pF	$\pm 10\%$	500 V	CERAMIC CAPACITOR
C19, 20	2551084007	0.1 μ F	$\pm 10\%$	50 V	PLASTIC FILM CAPACITOR
C21, 22, 23, 24 25, 26, 27, 28	2531053003	10000 pF	$\pm 100\%, -0\%$	500 V	CERAMIC CAPACITOR
C29, 30, 31, 32	2544059065	1 μ F		63 V	ELECTROLYTIC CAPACITOR
C33, 34, 35, 36	2544059007	100 μ F		63 V	ELECTROLYTIC CAPACITOR
C37, 38	2544015009	10 μ F		16 V	ELECTROLYTIC CAPACITOR
RESISTORS					
R1, 2	2410314009	1 kohm	$\pm 5\%$	1/4 W	CARBON FILM RESISTOR
R3, 4	2410355000	51 kohm	$\pm 5\%$	1/4 W	CARBON FILM RESISTOR
R5, 6, 7, 8	2410330009	4.7 kohm	$\pm 5\%$	1/4 W	CARBON FILM RESISTOR
R9, 10, 11, 12	2410350005	33 kohm	$\pm 5\%$	1/4 W	CARBON FILM RESISTOR
R13, 14, 15, 16 21, 22, 23, 24	2410340002	12 kohm	$\pm 5\%$	1/4 W	CARBON FILM RESISTOR
R17, 18, 19, 20 25, 26, 27, 28	2410356009	56 kohm	$\pm 5\%$	1/4 W	CARBON FILM RESISTOR
R29, 30, 31, 32, 71, 72	2410300000	270 ohm	$\pm 5\%$	1/4 W	CARBON FILM RESISTOR
R33, 34, 47, 48, 49, 50	2410334005	6.8 kohm	$\pm 5\%$	1/4 W	CARBON FILM RESISTOR
R35, 36, 37, 38	2410303007	360 ohm	$\pm 5\%$	1/4 W	CARBON FILM RESISTOR
R39, 40, 41, 42 43, 44, 45, 46	2410282005	47 ohm	$\pm 5\%$	1/4 W	CARBON FILM RESISTOR
R51, 52, 53, 54	2410319004	1.6 kohm	$\pm 5\%$	1/4 W	CARBON FILM RESISTOR
R55, 56, 57, 58	2440029005	100 ohm	$\pm 5\%$	1 W	METAL OXIDE FILM RESISTOR
R59, 60, 61, 62	2430037007	0.47 ohm	$\pm 10\%$	5 W	WIRE WOUND RESISTOR
R63, 64	2430045002	10 ohm	$\pm 10\%$	5 W	WIRE WOUND RESISTOR
R65, 66	2410266005	10 ohm	$\pm 5\%$	1/4 W	CARBON FILM RESISTOR
R67, 68, 69, 70	2440033004	220 ohm	$\pm 5\%$	1 W	METAL OXIDE FILM RESISTOR
OTHER PARTS					
VR1, 2	2116003041	VARIABLE RESISTOR		V10QB471	
VR3, 4	2116003009	VARIABLE RESISTOR		V10QB471	
	4170077105	POWER RADIATOR			
	4120372009	RADIATOR BRACKET (A)			
	4120373008	RADIATOR BRACKET (B)			
	2070002007	TR. SOCKET			
	4140116009	SHIELD CASE			
	EP-4772	CORD HOLDER			

POWER SWITCH & PROTECTOR UNIT ETC-262

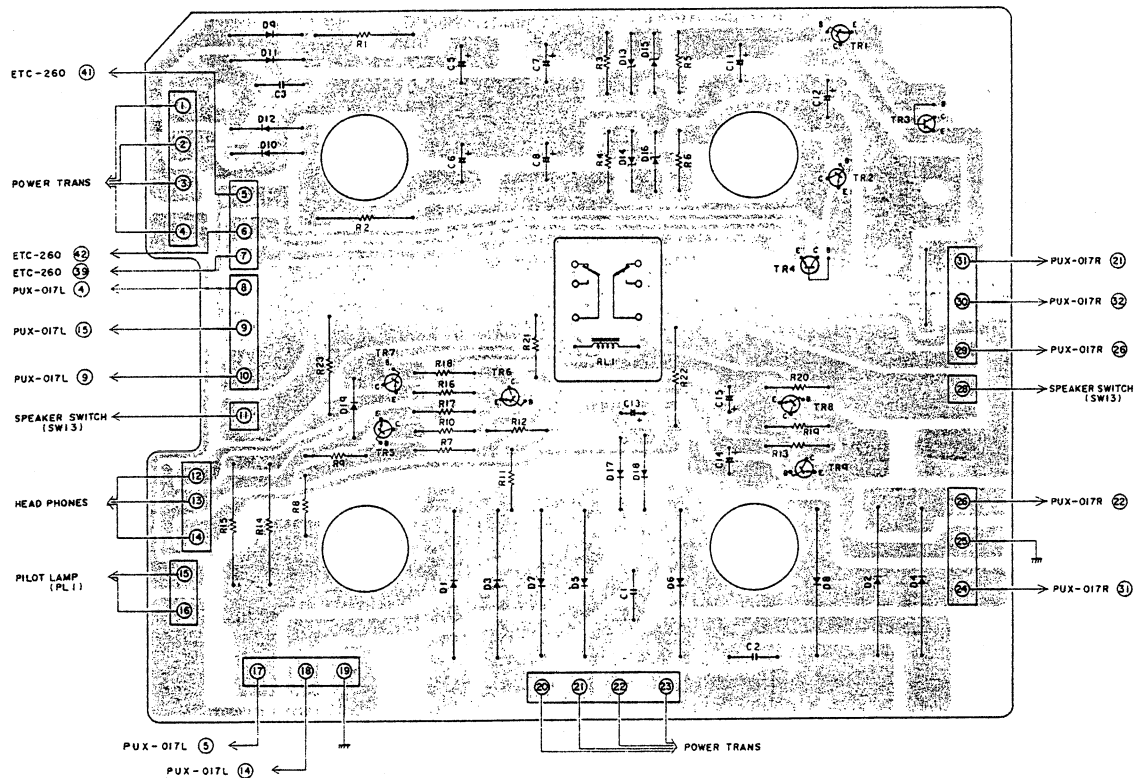
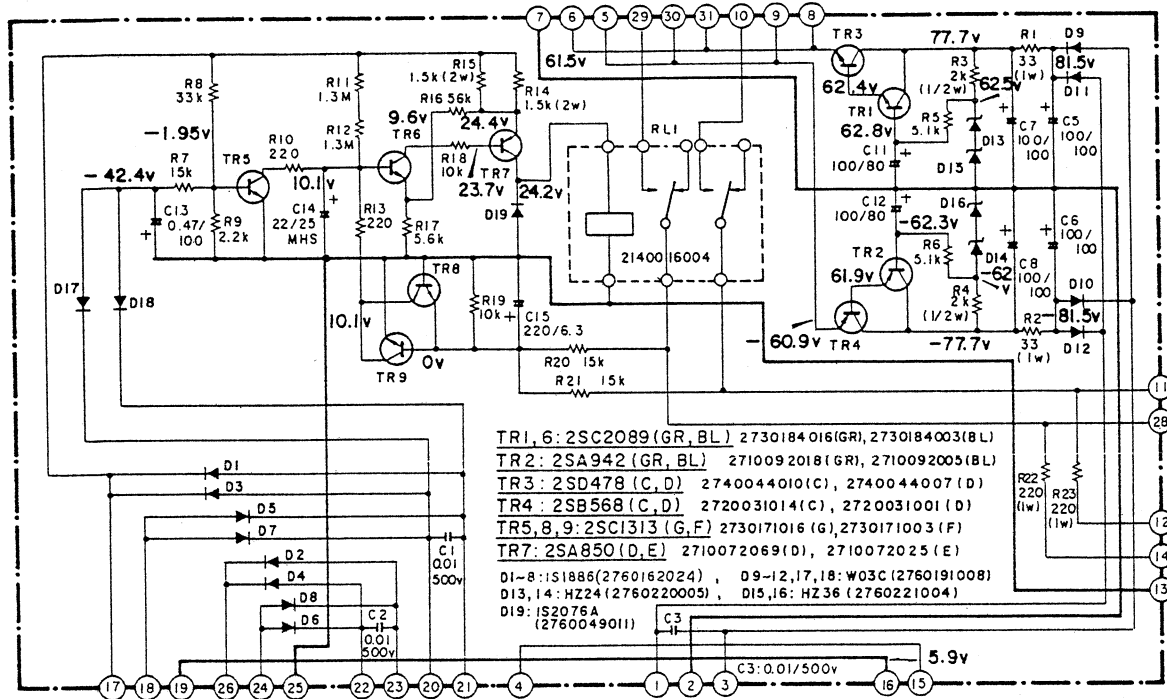

ETC-262 PARTS LIST

Ref. No.	Part No.	Descriptions
SEMICONDUCTORS		
TR1, 6	2730184016	2SC2089 (GR)
TR2	2710092018	2SA942 (GR)
TR3	2740044010	2SD478 (C)
TR4	2720031014	2SB568 (C)
TR5, 8, 9	2730171016	2SC1313 (G)
TR7	2710072009	2SA850 (D)
D1, 2, 3, 4, 5, 6, 7, 8	2760162024	1S1886
D9, 10, 11, 12, 17, 18	2760191008	W03C
D13, 14	2760220005	HZ24
D15, 16	2760221004	HZ36
D19	2760049011	1S2076A

Ref. No.	Part No.	Descriptions			
CAPACITORS					
C1, 2, 3	2531053003	10000 pF	+ 100%, - 0%	500 V	CERAMIC CAPACITOR
C5, 6, 7, 8	2544060012	100 μ F		100 V	ELECTROLYTIC CAPACITOR
C11, 12	2544063006	100 μ F		80 V	ELECTROLYTIC CAPACITOR
C13	2544060038	0.47 μ F		100 V	ELECTROLYTIC CAPACITOR
C14	2549005027	22 μ F	\pm 20%	25 V	ELECTROLYTIC CAPACITOR
C15	2544004007	220 μ F		6.3 V	ELECTROLYTIC CAPACITOR
RESISTORS					
R1, 2	2440023001	33 ohm	\pm 5%	1 W	METAL OXIDE FILM RESISTOR
R3, 4	2410192001	2 kohm	\pm 5%	1/2 W	CARBON FILM RESISTOR
R5, 6	2410331008	5.1 kohm	\pm 5%	1/4 W	CARBON FILM RESISTOR
R7, 20, 21	2410342000	15 kohm	\pm 5%	1/4 W	CARBON FILM RESISTOR
R8	2410350005	33 kohm	\pm 5%	1/4 W	CARBON FILM RESISTOR
R9	2410322004	2.2 kohm	\pm 5%	1/4 W	CARBON FILM RESISTOR
R10, 13	2410298002	220 ohm	\pm 5%	1/4 W	CARBON FILM RESISTOR
R11, 12	2410768008	1.3 Mohm	\pm 5%	1/4 W	CARBON FILM RESISTOR
R14, 15	2440100005	1.5 kohm	\pm 5%	2 W	METAL OXIDE FILM RESISTOR
R16	2410356009	56 kohm	\pm 5%	1/4 W	CARBON FILM RESISTOR
R17	2410332007	5.6 kohm	\pm 5%	1/4 W	CARBON FILM RESISTOR
R18, 19	2410338001	10 kohm	\pm 5%	1/4 W	CARBON FILM RESISTOR
R22, 23	2440033004	220 ohm	\pm 5%	1 W	METAL OXIDE FILM RESISTOR
OTHER PARTS					
RL1	2140016004	RELAY D.C. 24 V			
	4170078201	RADIATOR			

WIRING DIAGRAM

ETC-260 (2220359005)

ETC-259-2 (2220358006)

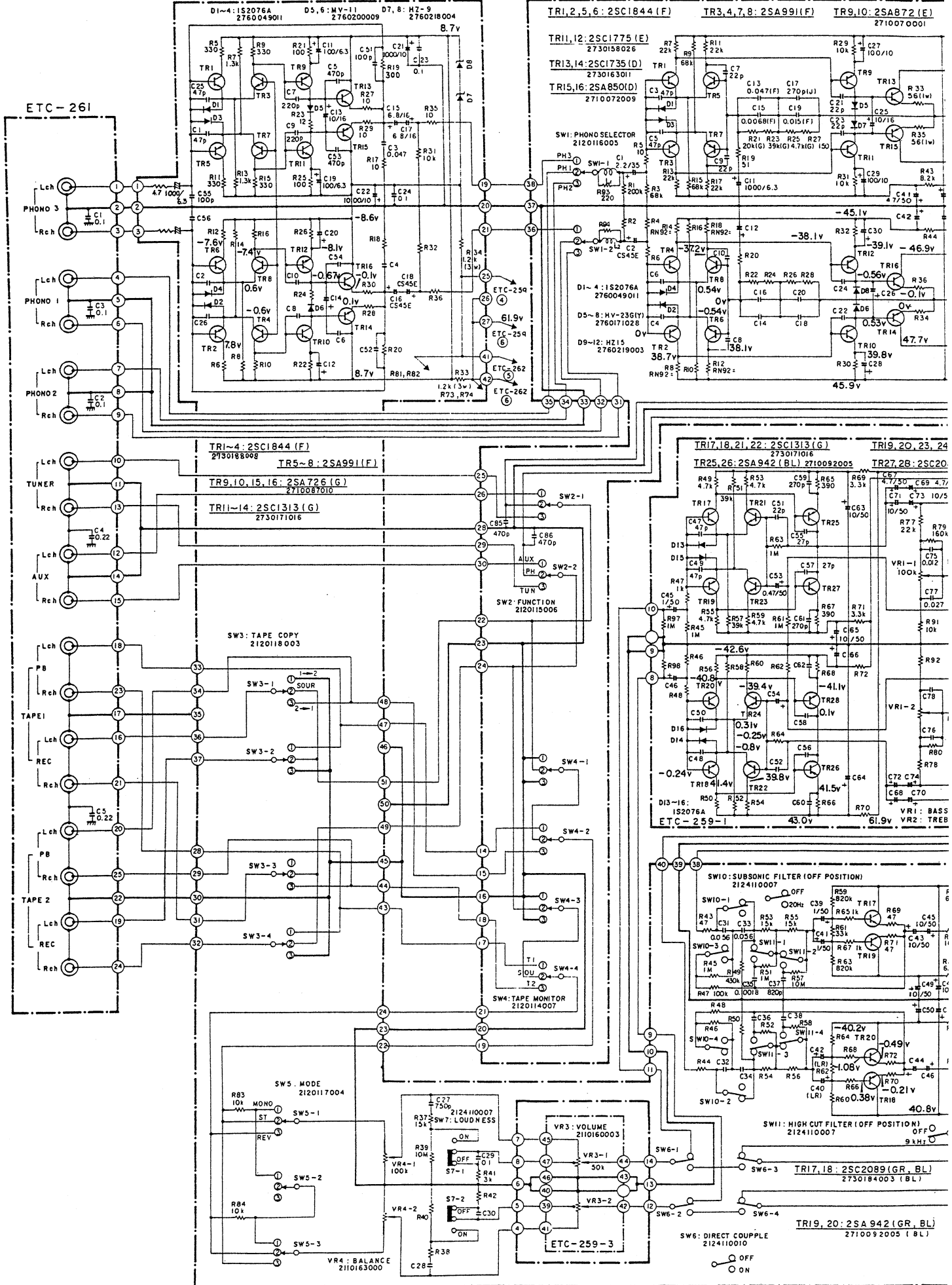

PUX-017B-L (2220367000)

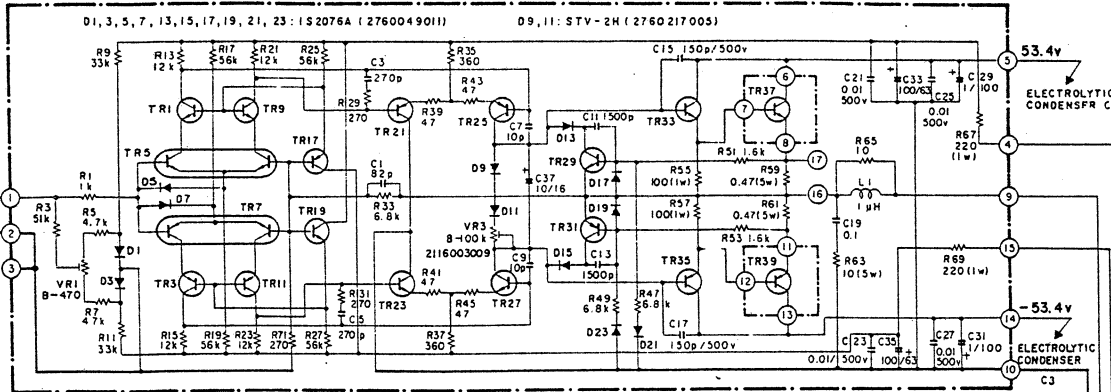

TR1, 9, 19: 2SC2089 (BL) 2730184003	TR3, 11, 17: 2SA942 (BL) 2710092005	TR5: 2SC1583 (G) 2730181006	TR7: 2SA798 (G) 2710073008
TR21, 25: 2SA915 (L) 2710093004	TR23, 27: 2SC1940 (L) 2730186001	TR29: 2SC1000 (GR) 2730098034	TR31: 2SA493 (GR) 2710012001
TR33: 2SC1624 (Y) 2730174000	TR35: 2SA814 (Y) 2710081003	TR37: 2SD551 (R) 2740056008	TR39: 2SB681 (R) 2720039003

PUX-017B-R

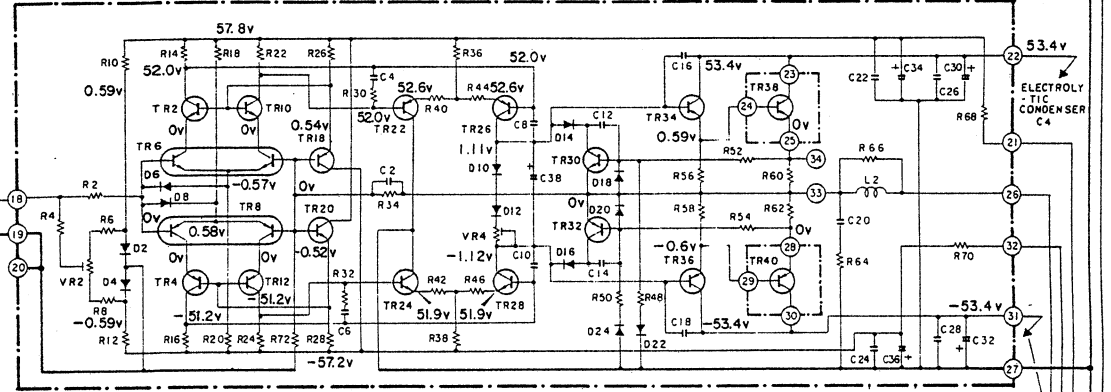

ETC-262 (2220361003)

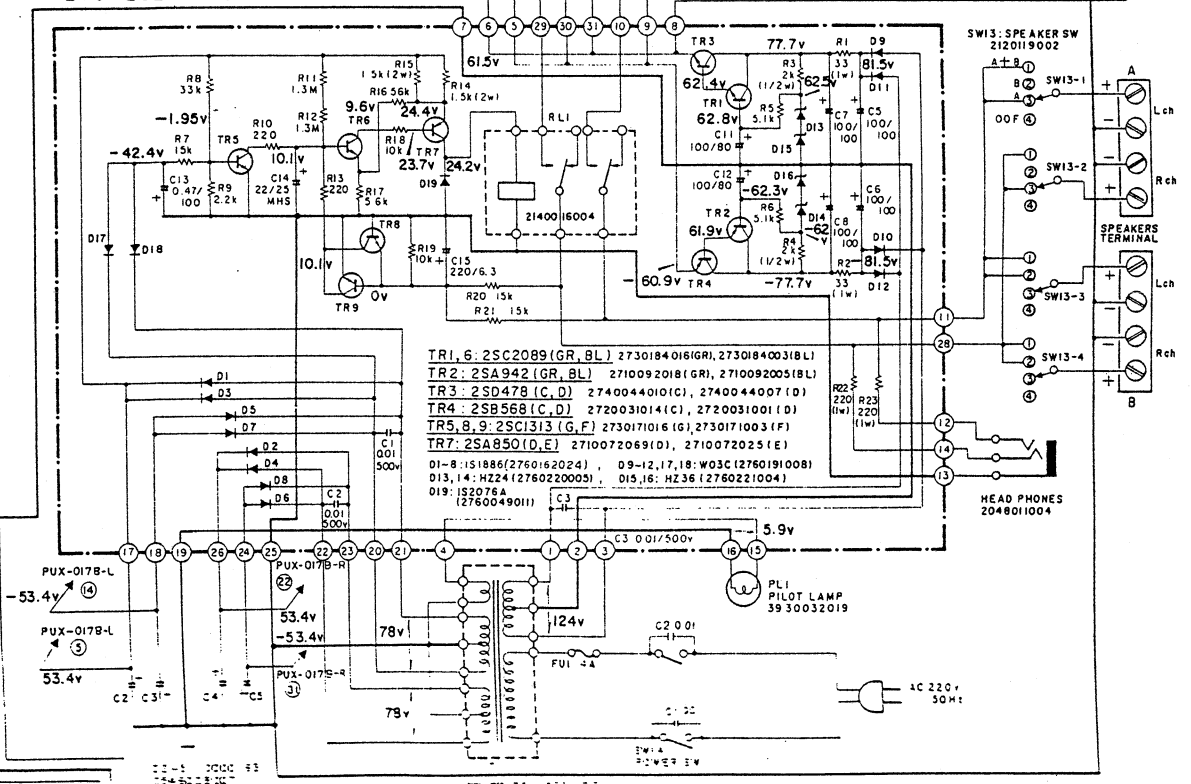

TR1, 6: 2SC2089 (GR, BL) 2730184016 (GR), 2730184003 (BL)	TR2: 2SA942 (GR, BL) 2710092018 (GR), 2710092005 (BL)
TR3: 2SD478 (C, D) 2740044010 (C), 2740044007 (D)	TR4: 2SB568 (C, D) 2720031014 (C), 2720031001 (D)
TR5, 8, 9: 2SC1313 (G, F) 2730171016 (G), 2730171003 (F)	TR7: 2SA850 (D, E) 2710072069 (D), 2710072025 (E)

D1-8: 1S1886 (2760162024), D9-12, 17, 18: W03C (2760191008)
D13, 14: HZ24 (2760220005), D15, 16: HZ36 (2760221004)
D19: 1S2076A (2760049011)

NOTES

ALL RESISTANCE VALUES IN OHM K = 1,000 OHM M = 1,000,000 OHM
 ALL CAPACITANCE VALUES IN MICRO FARAD P = MICRO-MICRO FARAD
 EACH VOLTAGE AND CURRENT ARE MEASURED AT NO SIGNAL INPUT CONDITION.
 CIRCUIT AND PARTS ARE SUBJECT TO CHANGE WITHOUT PRIOR NOTICE.

CHASSIS AND CABINET GROUP PARTS LIST

Part No.	Descriptions
1020063204	TOP COVER
4610094017	RUBBER SHEET
4610061118	RUBBER SHEET
4610061121	RUBBER SHEET
1220007057	SPACER
1050188308	BOTTOM COVER
1040040003	FOOT
1440344202	FRONT PANEL
1430041007	PILOT LENS
1190005040	BLIND SHEET
1120160007	KNOB ASS. FOR VOLUME
1120161006	KNOB ASS. FOR SPEAKER, BASS AND FUNCTION
1120162209	KNOB ASS. FOR PHONO, SELECTOR, TAPE AND FUNCTION
1120163101	KNOB ASS. FOR BALANCE, MODE AND REC. SELECTOR
1120166108	LEVER KNOB
SC-1162	SPECIAL SCREW
4770064107	FIXING SCREW
1050207205	BACK PANEL
ETC-261	INPUT TERMINAL UNIT
2050070004	8P. TERMINAL ASS. FOR SPEAKER
2050071003	TERMINAL ASS. FOR GND
4140057100	BOARD BRACKET
2061015087	FUSE 4A = TIME LUG
2020012005	FUSE HOLDER
2062016001	AC CORD WITH PLUG
4450020005	CORD BUSH
4110144302	FRONT CHASSIS
ETC-260	CONTROL (B) UNIT
2120119002	SPEAKER SWITCH
2048011101	HEADPHONE JACK
3930032019	PILOT LAMP 6.3 V 15 A
2124122008	LEVER SWITCH
4110147202	MAIN CHASSIS
MD-5271	P.C.B. SUPPORT
MD-4368	WIRE CLIP
MD-4232	WIRE CLIP (D)
2050095102	EARTH PLATE
PUX-017B-L	POWER AMP UNIT (L)
PUX-017B-R	POWER AMP UNIT (R)
4110148405	SIDE CHASSIS
ETC-259	CONTROL (A) UNIT
2335100000	POWER TRANSFORMER ASS.
ETC-262	POWER SWITCH & PROTECTOR UNIT
4450033005	WIRE CLAMP BAND
2050037005	SHORT PIN
4140114205	SHIELD COVER
4610074176	BLIND
4610074150	BLIND
2546028007	10000 μ F \pm 20% 63 V [Ref. No. C2, 3, 4, 5] ELECTROLYTIC CAPACITOR
2518001007	0.01 μ F \pm 20% OIL CAPACITOR